

FOCONO

Your Local

LED

Application



Outdoor Rental LED Display — S Series —

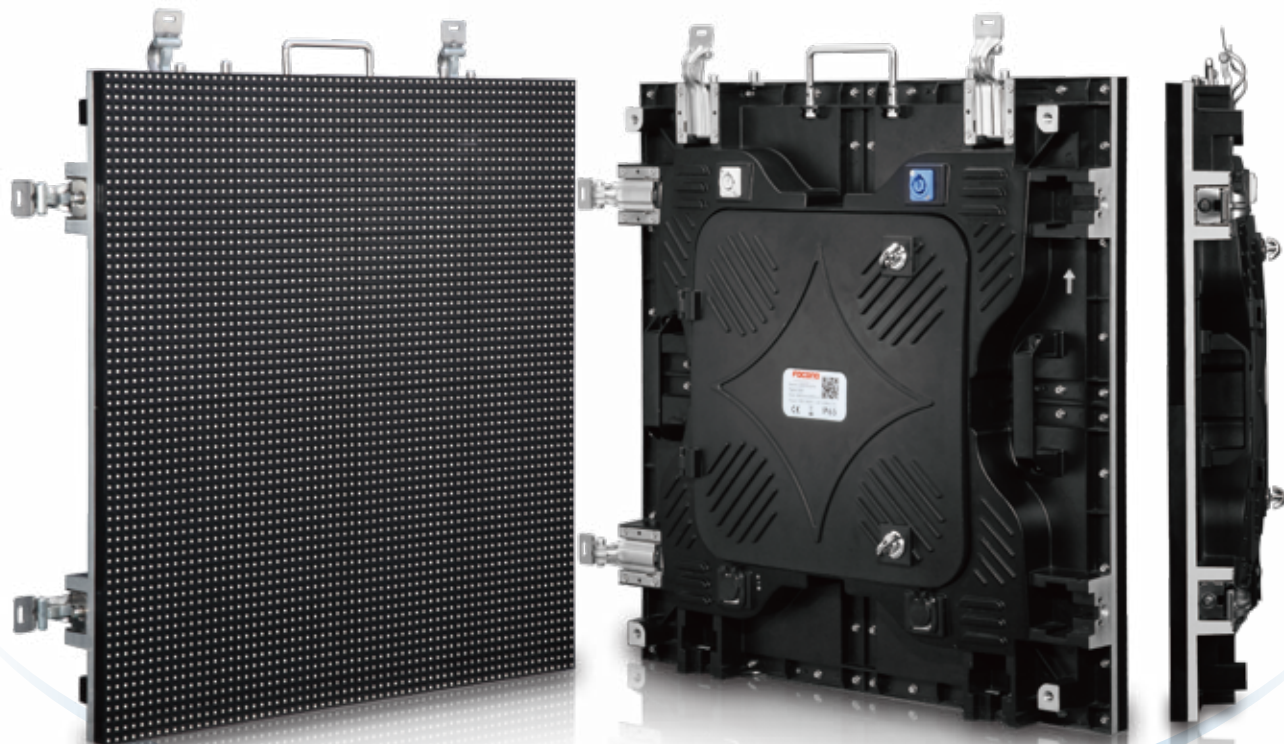

Lighter



Quiet operation



Fast
assembling



Diagnostic
indication

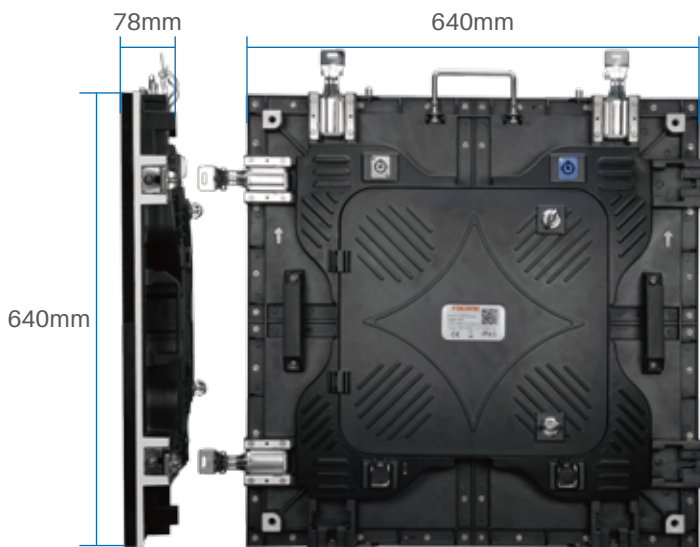

Lighter

Lighter and thinner

Decrease the transportation and labor cost.

Less noise design

Air fan free to eliminate the noise.



Quiet operation

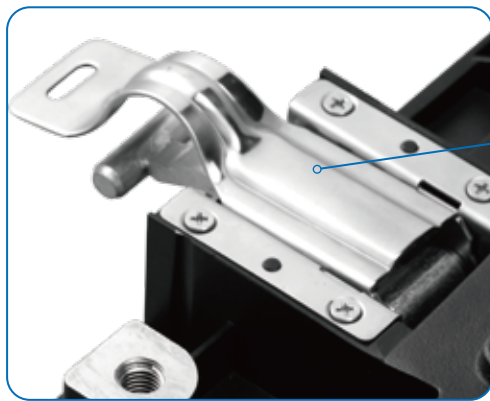

Fast assembling

Fast assembling

The side-lock assures the cabinet joint within 8 seconds.

Diagnostic indication

Visible mistake tracking function.



Diagnostic indication



4”H” performance

High brightness: 6000nits;
High refresh rate: 2000Hz;

High gray scale: 65536 levels;
High contrast ratio.



Vivid picture



High refresh rate

Parameters

Value	S8	S10
Pixel pitch	8mm	10mm
Brightness	5600 nits	6400 nits
Pixel configuration	SMD	SMD
Colours	281 trillion	281 trillion
Refresh rate	≥1800 Hz	≥2640 Hz
Pixel matrix per panel	80×80	64×64
Pixel matrix per sq.m	15625	10000
Viewing angle (H/V)	140/140 deg.	140/140 deg.
Power consumption (max/avg)	890/310 w/sq.m	910/310 w/sq.m
IP rate	IP65/IP43	IP65/IP43
Input voltage (AC)	110 / 240	110 / 240
Panel size(L x W x H)	640x640x78mm	640x640x78mm
Panel weight	15Kgs(Alu.)	15Kgs(Alu.)

Applications

Outdoor commercial advertising, sport, event, concert, musical festival, wntertainment etc. rental occasions.

